

ITEM NO.	DESCRIPTION	QTY.
1	2 AWG, 10 INDEX DIE SET	1

CATALOG NUMBER	DESCRIPTION
HW2CVT	2 AWG, 10 INDEX DIE SET

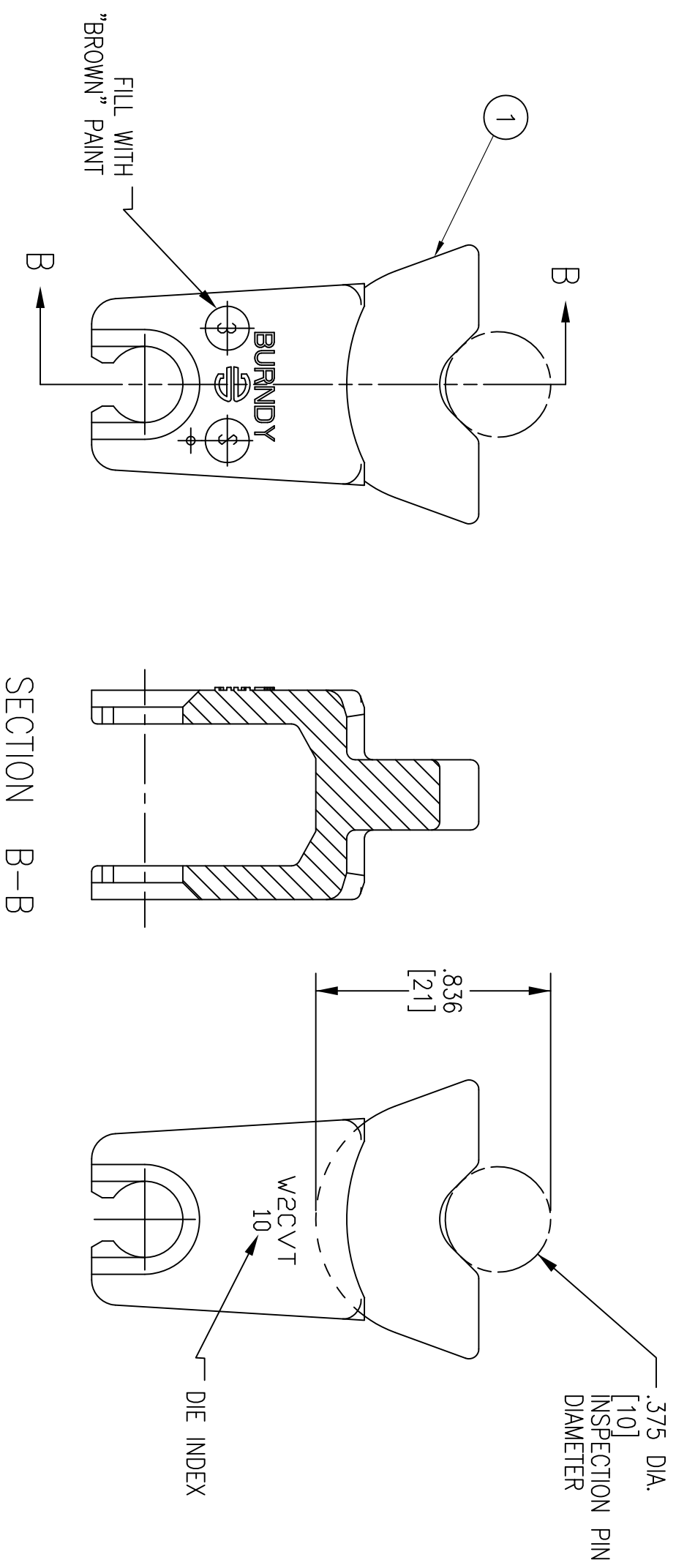

SECTION B-B

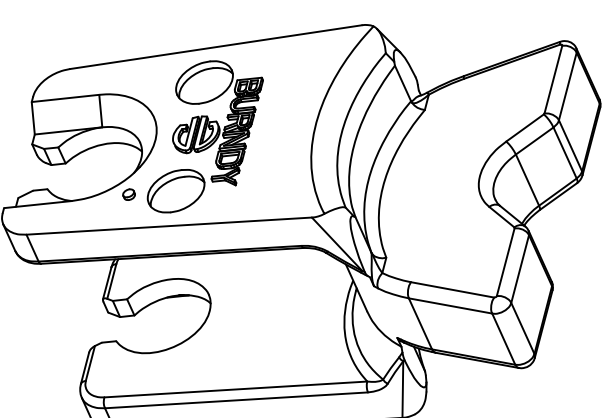

NOTES:

1. DIMENSIONS IN BRACKETS [] ARE IN MILLIMETERS ROUNDED OFF TO THE NEAREST MILLIMETER. UNLESS OTHERWISE NOTED, AND ARE FOR REFERENCE ONLY.
2. MATERIAL: STAINLESS STEEL
3. CATALOG NUMBER CONSIST OF TWO DIE HALVES.
4. SPECIFICATIONS SUBJECT TO CHANGE WITHOUT NOTICE.
5. FITS HPAT600LI AND HMD7 COMPRESSION TOOLS.
6. SPECIFICATIONS SUBJECT TO CHANGE WITHOUT NOTICE.

REV.	ECN	DATE	DESCRIPTION	CHG BY	APPD BY
1	17987	8/13/12	INITIAL RELEASE	CG	

Created on AUTOCAD		<p>DIMENSIONING AND TOLERANCE PER ANSI Y14.5M-1982 UNLESS OTHERWISE SPECIFIED, DIMENSIONS ARE IN INCHES (MM). TOLERANCES .XX = ±.01 (.25) .XXX = ±.005 (.127) .XXXX = ±.0025 (.0635) ANGLE TOL ±1°</p>	
<p>PROJECT REFERENCE: 2011-041</p>		<p>MATERIAL: SEE NOTES</p>	
<p>DRAWN BY: C. GRIBBLE 8/13/12</p>		<p>IN ACCEPTING OUR DRAWINGS, BLUEPRINTS, OR SUPPORTING DOCUMENTATION FOR QUOTATION OR OTHER PURPOSES, YOU AGREE NOT TO DISCLOSE TO OTHERS THE IDEAS, INFORMATION, OR DESIGNS SHOWN HEREIN, AND THAT YOU WILL MAKE NO USE OF SAME WITHOUT PERMISSION</p>	
<p>CHECKED BY:</p>		<p>APPROVED BY:</p>	
<p>SIZE: DRAWING NO. C HW514106C</p>		<p>TITLE: DIE SET, 2 AWG, 10 INDEX W DIE SET FAMILY</p>	
<p>SCALE: 1/1</p>		<p>SHEET 1 OF 1</p>	
		<p>REV. 1</p>	

A

B

C

D

A

B

C

D